

# CROSS-OVER LADDER - COL-5-46-44-HDG

APPROX WEIGHT: 423.71 lbs.  
 DOES NOT INCLUDE WEIGHT OF POWER OR PACKAGING!!!

\*\*\* ANY ADDITIONS, DELETIONS, OR OMISSIONS MUST BE CORRECTED ON THIS DRAWING AS THIS DRAWING WILL BE CONSIDERED ALL INCLUSIVE \*\*\*

ALL GRAPHICS PROVIDED ARE FOR REFERENCE ONLY. IF CERTAIN DIMENSIONS ARE CRITICAL PLEASE VERIFY THOSE DIMENSIONS WITH YOUR SALESPERSON

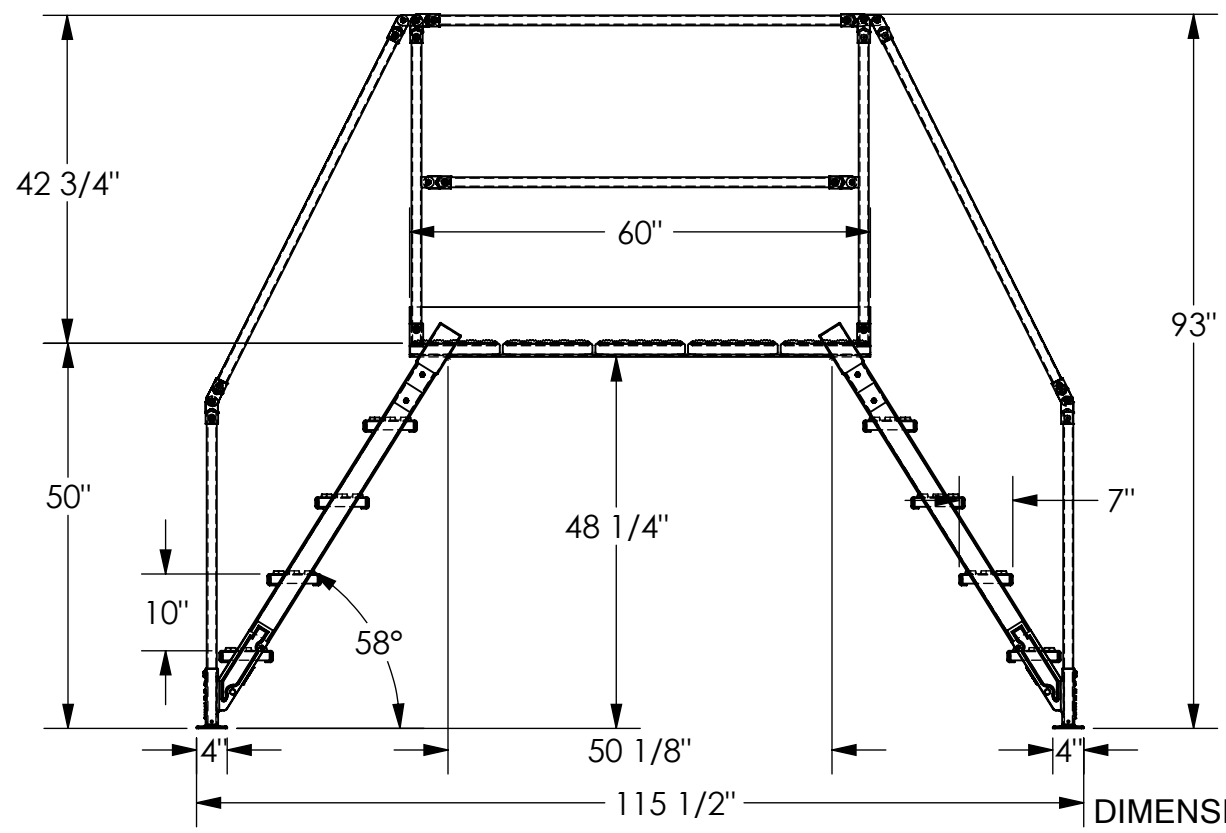
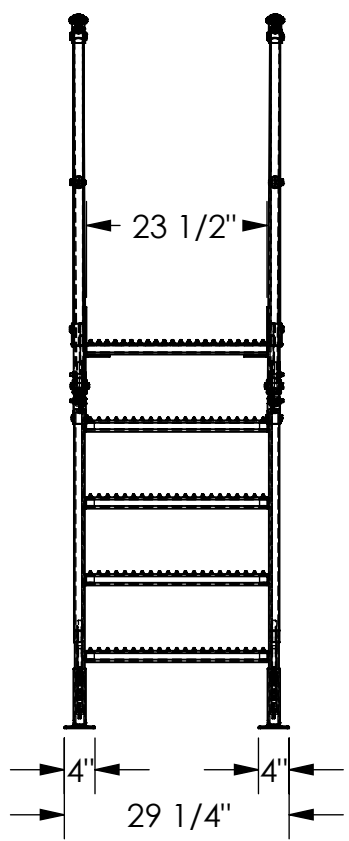

**DIMENSION TOLERANCE ± 1/4"**

## STANDARD FEATURES

MODEL NUMBER: COL-5-46-44-HDG  
 OVERALL SIZE:  
 29 1/4" W x 115 1/2" L x 93" H  
 CLEARANCE SPAN:  
 50 1/8" W x 48 1/4" H  
 TOP PLATFORM HEIGHT: 50"  
 STEP HEIGHT SPACING: 10"  
 STEP DEPTH: 7"  
 STEP & PLATFORM WIDTH 23 1/2"  
 CLIMB ANGLE: 58°  
 HOT DIPPED GALVANIZED FINISH  
 HANDRAILS ARE TOUGH BAKED IN POWDER COATED YELLOW FINISH  
 ALL STEPS & PLATFORM ARE SERRATED STEEL  
 KNOCK-DOWN HANDRAILING  
 (UNIT SHIPS KNOCKED DOWN, ASSEMBLY REQUIRED)

## SPECIAL FEATURES

NONE

## NOTE

UNIT MUST BE ANCHORED TO THE FLOOR!!!  
 Ø7/16" MOUNTING HOLES  
 8 TOTAL MOUNTING HOLES PER  
 STANDARD UNIT  
 2 MOUNTING HOLES PER CORNER  
 BRACKET

**APPROVAL**

I, THE UNDERSIGNED, AGREE THAT THE PRODUCT AS REPRESENTED SATISFIES DESIGN AND DIMENSION REQUIREMENTS. I ALSO ACKNOWLEDGE MY DUTY TO CONFIRM PRODUCT AND INSTALLATION COMPLIANCE WITH ALL APPLICABLE FEDERAL, STATE AND LOCAL REGULATIONS AND STANDARDS.

**UNITS REQUIRING APPROVAL DRAWINGS OR MODIFIED ARE NON-RETURNABLE**  
 As drawn       As marked

Signed: \_\_\_\_\_ Date: \_\_\_\_\_  
 Printed Name: \_\_\_\_\_

**LEAD TIME WILL START UPON RECEIPT OF SIGNED APPROVAL DRAWING**

DISTRIBUTOR'S NAME:		P.O.#
VESTIL MANUFACTURING		X
DRAWN BY: BCN		W.O.#
DATE: 4/29/2016		X
REFERENCE: X	SCALE: 1:25	SALES: X
QUOTED LEAD TIME: X	QUOTE #	FILE NAME:
	X	44-007-739